

UNIVERSAL LATHE WITH CYCLING-CONTROLLED UNIT

Family PD

**PD 1300 CM, PD 1600 CM, PD1800 CM, PD 2000 CM
with Fagor 8055 control unit**

Universal lathes with family and cyclical controlled lathes are designed for the demands of the market guided by the principles of modern design and traditional quality.

The lathe from the family PD-CM has been constructed based on a completely new concept, which means a new attitude to the communication between man and machine.

On the other hand, it is possible to operate the machine in cycle as chosen from the MENU of the control unit.

The basic philosophy of the machine could be defined as a direct interaction between man and machine based on a very simple communication language and on the expertise of the operator. With this possibility the need for wide-ranging and expensive education of the operator has been avoided.

Figuratively speaking, "the man dominates the machine" again.

As a result of the above mentioned concept the lathe is suitable for processing of individual work-pieces, for small series and for middle-range series of production.

The machine has a line of programmable automatic cycles. The programs for each cycle can be stored in the controlled unit (FAGOR 800 T CNC) with a keyboard marked with symbols, for the following operations:

- Longitudinal turning; frontal turning; taper turning; radial turning (and of balls);
- Thread cutting (including taper threads); cutting (radial and axial);
- Turning of contours;



Universal lathe with cycling control unit PD 1300 CM

The main advantages of machines:

- ❑ Solid, stable and wide base with induction tempered prism with a large surface of incumbency. Sliding surface hardness is 50 HRC
- ❑ The width of the base is 710mm, and 1120mm.
- ❑ Large sliding surface of the slider with a small surface pressure provided great guidance and ability to maintain long-term accuracy. Sliding surfaces are coated with TURCIT B.
- ❑ Management of the slider on three prisms (two up and one with a front of the base) provides high stability at higher cutting without vibration modes
- ❑ Headstock is a massive construction with a main spindle spaced with three high quality bearings, that assure to machine high massiveness and precision.
- ❑ All rotary elements of headstock are heat treated and polished.
- ❑ The machine is suitable for removal of large sections of the chip rough treatment without vibration and for fine processing with high accuracy. The accuracy of machines according to DIN 8607th
- ❑ Large machine maximum torque of 16000 Nm.

1. DESCRIPTION OF THE WORK OF MACHINE

The PA Family lathe with FAGOR control unit offers three regimes of possible operation, namely:

1. MANUAL OPERATION REGIME

Work in this regime is performed the same way as on conventional lathes.

The operator has **two electric hand-wheels** at disposal for the adjustment of the longitudinal and cross slides. During the adjustment the screen of the control unit (as a digital indicator) displays the movements along the axes “z” and “x”.

At the same time, the operator can follow the revolution number of the spindle and the feed rate.

With the use of the “CSS” push-button constant cutting speed is ensured, i.e., the revolution number changes automatically depending on the diameter of the lathe-work.

Operation in manual regime with the help of hand-wheels for “z” and “x” axes is very easy. Joystick is used for the start of longitudinal and cross feed movements.

2. SEMI-AUTOMATIC OPERATION REGIME

Simple operations such as, for example, longitudinal turning can be programmed by the operator with the data on the starting and concluding turning points, after what the **processing can be performed automatically as one processing cycle**.

The machine has the possibility to be programmed during manual operation regime (TEACH-IN PROGRAMMING). The meaning of this is that the machine memorizes the starting and concluding points of every finished processing cycle after what it is possible to repeat the same processing cycle in the automatic regime.



3. AUTOMATIC OPERATION REGIME

The PA-CM family lathe is capable of performing **the complete processing automatically**, during what it displays the course of processing graphically and numerically on the screen of the control unit with the aim of an easier follow up of the whole operation.

The program can be stored in the control unit and to be used thereafter when needed.

Programming of the processing cycles is **very easy** and it does not require particular knowledge about programming from the operator.

2. TECHNICAL SPECIFICATION

Technical specification / Technische Daten		PD1300	PD1600	PD2000
  				
Working range / Arbeitsbereich				
Distance between centres / Spitzenweite	mm	2000-10000		
Swing diameter above bed / Umlaufdurchmesser über dem Bett	mm	1300	1600	2000
Swing diameter above cross slide / Drehdurchmesser über dem Querschlitzen	mm	1000	1200	1600
Diameter of faceplate / Durchmesser der Planscheibe	mm	1120	1600	1600
Tool cross section / Drehmeißelquerschnitt	mm	50x32	60x40	60x40
Headstock and spindle / Hauptspindel				
Spindle nose / Spindelkopf	DIN	55027	55026	
	No	11	15	
Spindle bore / Spindelbohrung	mm	130	210	210
Spindle diameter at front bearing / Spindeldurchmesser im vorderen Lager	mm	190	260	260
Spindle rpm / Drehzahl				
Range I / Stufe I	min ⁻¹	1-159	1-69	
Range II / Stufe II	min ⁻¹	160-317	70-140	
Range III / Stufe III	min ⁻¹	318-800	141-500	
Bed and slideways / Bett und Werkzeugträger				
Bed width / Bettbreite	mm	710	1120	1120
Width of carriage / Länge des Längsschlittens	mm	1000	1200	1200
Travel of cross slide / Querschlitzenweg	mm	660	1000	1000
Max. feed rate x/z-axis / Eilgang X/Z Achse	m/min	5		
Motor power / Antriebe (AC)				
Main drive / Hauptantriebsleistung	KW	37/56		
Transverse drive / Quervorschubantrieb	KW	2,49		
Longitudinal drive / Längsvorschubantrieb	KW	4,36		
Tailstock / Reitstock				
Quill diameter / Pinolendurchmesser	mm	160	220	220
Quill taper / Pinolenkegel	Morse	6	ME80	ME80
Maximum workpiece weights / Maximale Werkstückgewichte				
Between centres with one steady / Zwischen den Spitzen mit einer Lünette	kg	6300	16000	16000
Between centres with two steadies / Zwischen den Spitzen mit zwei Lünetten	kg	8000	20000	20000
Unsupported from one end / Fliegend gespannt	kg	1500	2500	2500
Weight of machine / Gewicht der Maschine (L=2000mm)				
Weight / Gewicht	kg	13000	21000	23000
Additional for every meter / Jeder hinzugefügte Meter	kg	1000	1500	1500
Maximum torque at faceplate / Max. Drehmoment	Nm	9400	16000	16000



PD1800CM		
Working range		
Distance between centers	mm	2000-10000
Swing over bed	mm	1800
Swing over cross slide	mm	1400
Diameter of Faceplate	mm	1600
Tool cross section	mm	60x40
Headstock and Spindle		
Spindle nose	DIN	55026
	No	15
Spindle bore	mm	210
Spindle diameter at front bearing	mm	190
Spindle revolutions range		
I		
Range	min ¹	1.-69
II		
Range	min ¹	70-140
III		
Range	min ¹	141-500
Bed and slideways		
Bed width	mm	1120
Carriage width	mm	1200
Cross slide travel	mm	1000
Rapid traverse X/Z axes	m/min	5
Main drive		
Main motor power	KW	37/56
Tailstock		
Quill diameter	mm	220
Quill taper	Morse	ME 80
Weight of the machine (L=2000mm)		
Weight	kg	22000
Addition for 1 m	kg	1500
Maximum Torque	Nm	16000

3. BED

The bed of the lathe is made of quality grey cast of homogenous structure. Subsequent deformations are avoided by natural and artificial aging.

The bed is wide (710mm, 1120mm) and massive.

The guideways are casted and induction hardened at approximately 50 HRC.

The front side is the third prism support system for the slider, which is given additional machine stability.

The chip is guided into the rear side of the bed with the help of the oblique-shaped walls of the bed.

All the assemblies of the machine are installed onto the bed, except for the reservoir of the coolant.



4. HEAD-STOCK

The head-stock as transmitter of the main motion, together with the regulated DC main drive electric-motor, provide the possibility of choosing the regime of work, with continual change of revolution numbers in the realms of three revolution number ranges.

The power transmission from the main drive to the entry shaft is through V-belts.

Change of revolution numbers is through moving of the bearing-pairs with the handles.

The shaft and bearings of the head-stock are heat treated and super fine – grinded. The spindle is with ending DIN 55021, size 11.

It is installed with two taper roller-and with one roller bearing.

All moving parts in the head-stock are lubricated artificially with a cog pump.



5. MAIN DRIVE

The main drive is provided through a DC motor. The electric-motor is located near the bed, left from the head-stock. The tightening of the V-belts can be adjusted by moving the holders of the electric-motor along the “T” grooves.

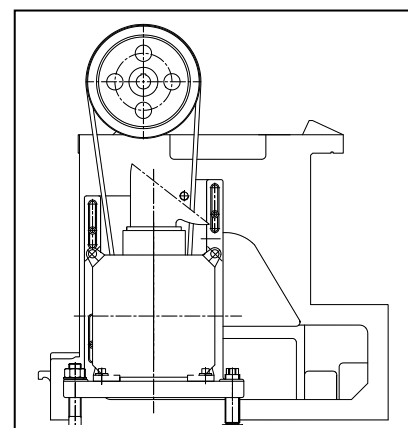

6. THE SYSTEM OF SLIDERS

The system of slides consists of:

- The saddle
- The cross slide



The sliding surfaces of the saddle and of the cross slide are coated with coating TURCIT B.

The saddle at the guide ways of the cross slide are induction tempered at around **45 HRC**. In prisms guide ways the front of the stands are guides to improve the stability of the slider. In this way the system is guided by the slider over three prisms.



□ "Z"AXIS DRIVE

It is located under the head-stock on the front side of the bed.

The drive (1) is connected through a timing belt (2) to the pulley (3). The pulley is set on a spiral bevel gear (4).

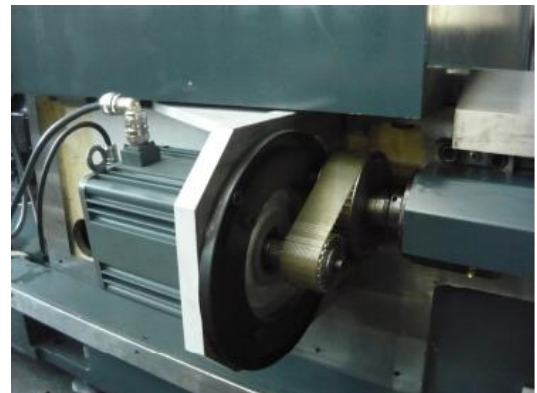

□ "X"AXIS DRIVE

It is located on the rear side of the slides.

The drive (1) is connected through a timing belt (2) to the pulley (3), which is located on a spiral bevel gear (4).

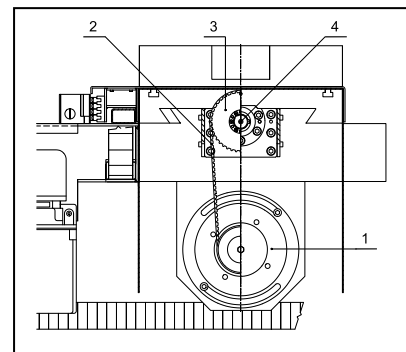

7. THE TAIL-STOCK

The tail-stock or the center carrier is located on the right side of the lathe on the guide ways. The tail-stock is massive part with a long body and a long tail-stock sleeve.

Massive producing allows the processing of heavy work-pieces. The primary producing, the tail-stock comes with an electric device for fast scrolling.



8. THE COOLING SYSTEM

The cooling system is located on the rear side of the lathe.

It consists of the reservoir (1) for the coolant (liquid), of supply pipes (2) located in the hoisting chain and of a tap with a flexible steel pipe installed onto the saddle. The flow of the liquid is started with a pump (3). The capacity of the pump according to the Q-H diagram of the manufacturer is 50 lit/min. up to the high of 2 m. The necessary coolant quantity depends on the length of the lathe and of the length of the coolant reservoir, according to the following:

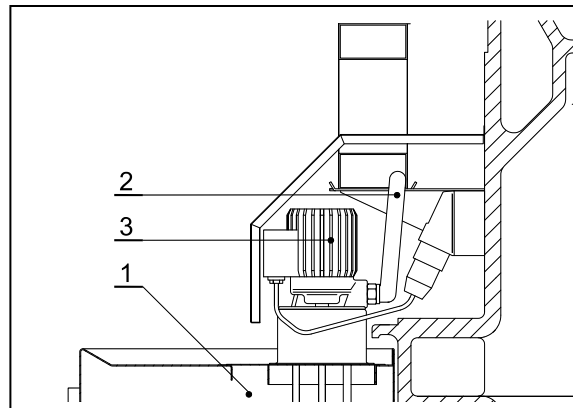

Distance between centers 1000 – 80 liters

Distance between centers 2000 – 120 liters

Distance between centers 3000 – 160 liters

9.THE CONTROL UNIT

In standard production it is installed into machine- Fagor 8055.

The control unit is made of three elements, namely:

- 11" LCD screen with installed ALFA-numerical keyboard,
- keyboard,
- Central unit,

The control unit enables programming for more automatic operations, the choice of which is facilitated with specific symbols on the keyboard

CNC-program language (C, M, S, T)

TEACH-IN

INTERACTIV EDITOR

HIGH-LEVEL program language

Each of the operations has two execution levels:

- Semi-automatic,
- Automatic,



On the consoles of control unit there are two electric hand wheels for manual work of lathe.





STANDARD ACCESSORIES

- FAGOR 8055 control
- work light 24V
- tool post type Multifix D1
- Central lubrication system
- Central lubrication system for longitudinal and cross support
- protection door-2 Pcs
- coolant system
- manual tailstock with electrical displacement
- electro equipment for connection to the network 3*380 V; 50Hz
- CE conformity

OPTIONAL ACCESSORIES

FANUC control 0 iTD manual guide
SIEMENS SINUMERIK 802 D
SIEMENS SINUMERIK 840 D Shop Turn

4-position tool turret SAUTER 0.5.320.025
6-position tool turret SAUTER 0.5.320.025
8- position disc tool turret SAUTER 0.5.480.525
12- position disc tool turret SAUTER 0.5.480.525
8 - position disc tool turret live tools SAUTER 0.5.473.525
12- position disc tool turret live tools SAUTER 0.5.473.525
4- position tool post PARAT D4

3-jaw chuck	Rohm DIN6350	Ø630
4-jaw chuck	Rohm DIN6350	Ø630

Chip conveyer

L=2000
L=3000
L=4000
L=5000
L=6000
L=8000
L=10000

Hydraulic tailstock with hydraulic unit
Drilling unit (Bohrbock) Ø120 L=1200mm
Drilling unit max Ø50mm,
Motor power 11KW, rpm 3000



Follow rest Ø50-350
Steady rest Ø50-450
 Ø120-620
 Ø480-720
 Ø400-800

1°spindle-indexing
C-axes, positioning accuracy 0,05°
Second reference point

Face plate 4 jaw Ø850
Face plate 4 jaw Ø1120
Face plate 4 jaw Ø1600

Completely closed working area
Painting of machine in accordance to customer's wish

Other optional accessories on request